

ENGINE COMPONENT ASSEMBLY

BASE PROCEDURE 23—ASSEMBLY

CYLINDER HEAD INSTALLATION

(Continued)

6. Install the timing belt tensioner spring stop stud into the cylinder head. Torque it to 19 to 29 N·m (14 to 21 lb-ft).

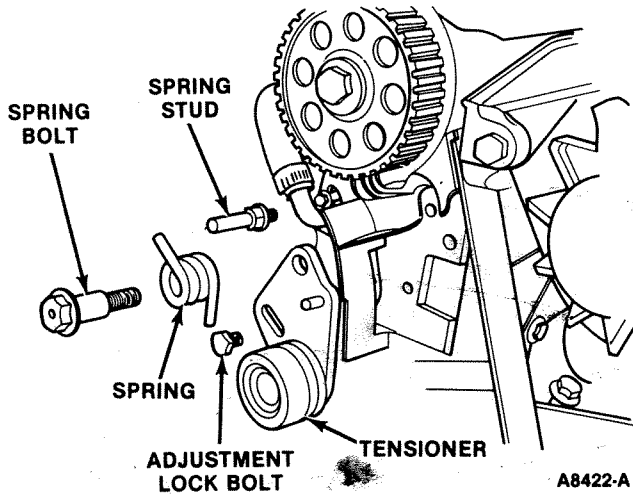

8. Torque them in two steps. During the first step, tighten to 7 to 9 N·m (5 to 7 lb-ft); during the final step, tighten to 23 to 31 N·m (16 to 23 lb-ft). Be sure to follow the proper torque sequence.

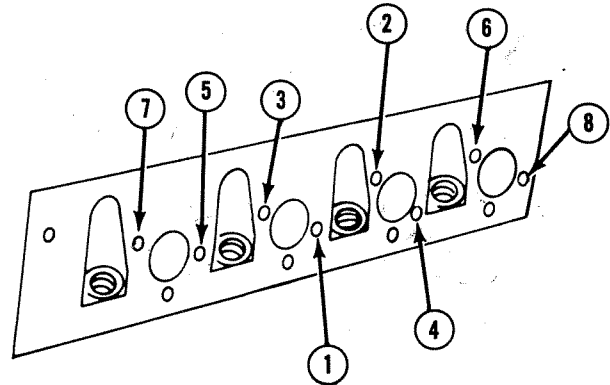

7. Position the exhaust manifold on the cylinder head and install the attaching bolts.

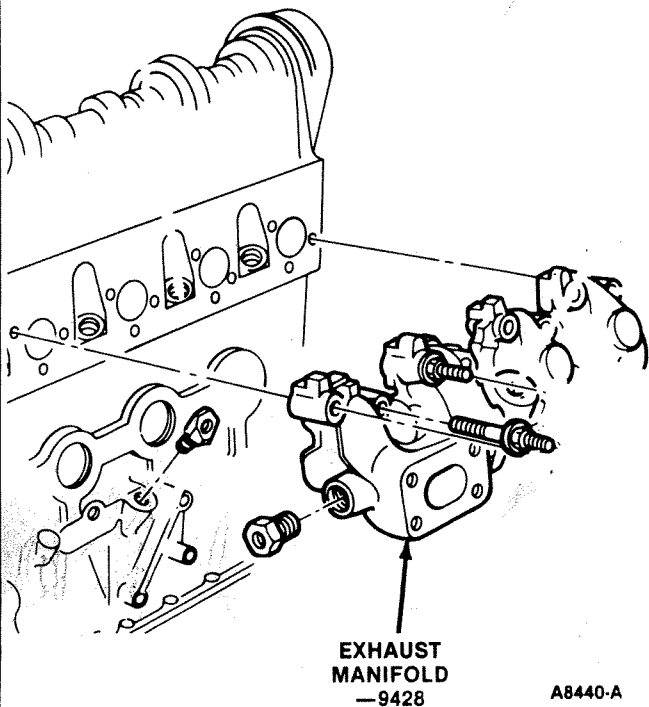

9. Install the alternator bracket-to-cylinder head bolts.

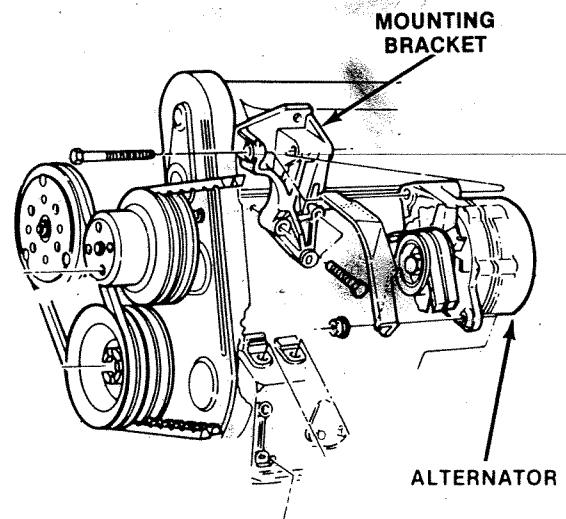

ENGINE COMPONENT ASSEMBLY**BASE PROCEDURE 23—ASSEMBLY****CYLINDER HEAD INSTALLATION
(Continued)**

Then complete:

- Base Procedure 21—Assembly, Fuel Supply Manifold Installation
- Base Procedure 18—Assembly, Timing Belt Inner Cover Installation
- Base Procedure 16—Assembly, Auxiliary Sprocket Installation
- Base Procedure 15—Assembly, Timing Belt Tensioner Installation
- Base Procedure 13—Assembly, Camshaft Sprocket or Seal Installation
- Base Procedure 12—Assembly, Timing Belt Installation
- Base Procedure 14—Assembly, Crankshaft Damper and Pulley Installation
- Base Procedure 7—Assembly, Timing Belt Cover Installation
- Base Procedure 6—Assembly, Water Pump Pulley Installation
- Base Procedure 5—Assembly, Drive Belts Installation
- Base Procedure 9—Assembly, Rocker Arm Cover Installation

BASE PROCEDURE 22—ASSEMBLY**LOWER INTAKE MANIFOLD INSTALLATION**

Refer to Section 24-29 for a complete description of Lower Intake Manifold removal and installation.

BASE PROCEDURE 21—ASSEMBLY**FUEL SUPPLY MANIFOLD INSTALLATION**

Refer to Section 24-29 for a complete description of the fuel supply manifold removal and installation procedure.

**BASE PROCEDURE 20—ASSEMBLY
UPPER INTAKE MANIFOLD INSTALLATION**

Refer to Section 24-29 for a complete description of upper intake manifold removal and installation procedure.

BASE PROCEDURE 19—ASSEMBLY**EXHAUST MANIFOLD INSTALLATION**

1. Be sure the exhaust manifold and the manifold surfaces on the cylinder head are clean.

ENGINE COMPONENT ASSEMBLY

**BASE PROCEDURE 19—ASSEMBLY
EXHAUST MANIFOLD INSTALLATION
(Continued)**

2. Install the exhaust manifold-to-cylinder head bolts. Torque them in two steps. During the first step, tighten to 20 to 23 N·m (177 to 204 lb-in.); during the final step, tighten to 27 to 41 N·m (20 to 30 lb-ft). Be sure to follow the proper torque sequence.

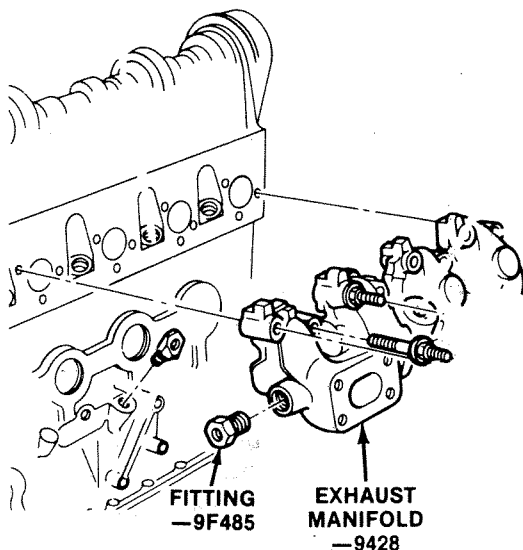
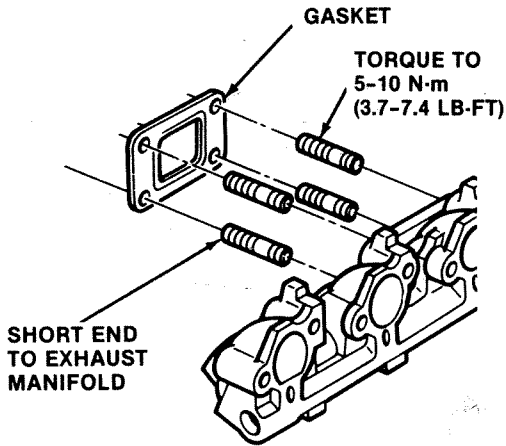
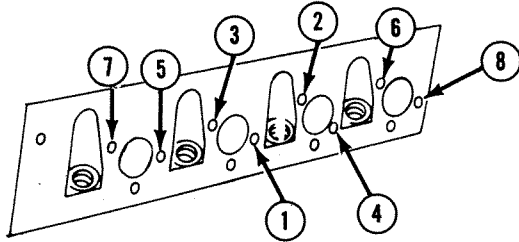

A8440-A

3. Install the turbocharger support bracket.
4. Install the turbo-to-exhaust manifold nuts.

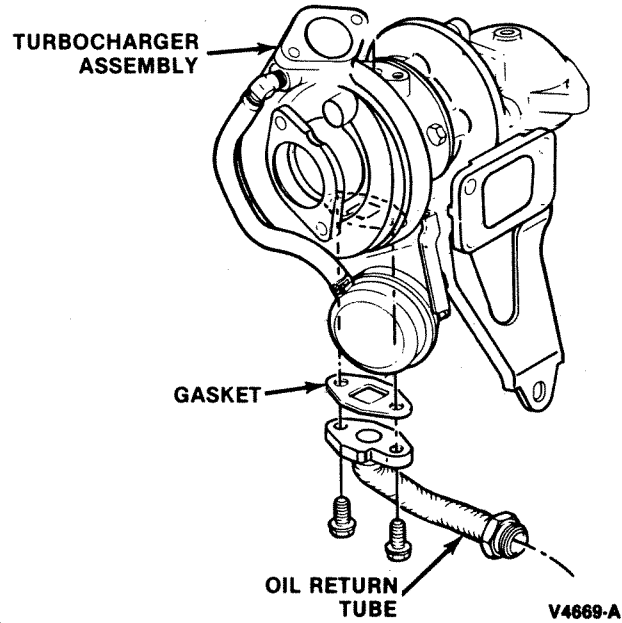

5. Connect the PCV tube at the turbo air inlet adapter.
6. Connect the turbo coolant supply tube at the turbocharger.
7. Connect the turbo oil supply line at the turbocharger.

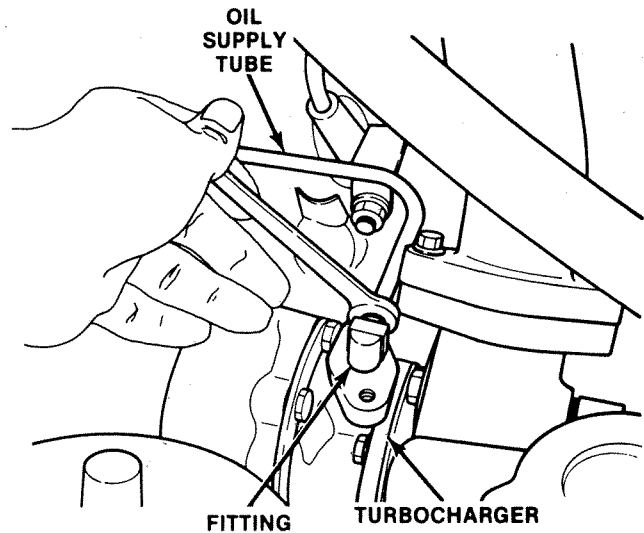

V4661-A

ENGINE COMPONENT ASSEMBLY

BASE PROCEDURE 19—ASSEMBLY

EXHAUST MANIFOLD INSTALLATION
(Continued)

8. Install the heater pipe-to-coolant expansion tank hose at the heater pipe.
9. Install the coolant pipe retaining clip screw at the rocker arm cover.

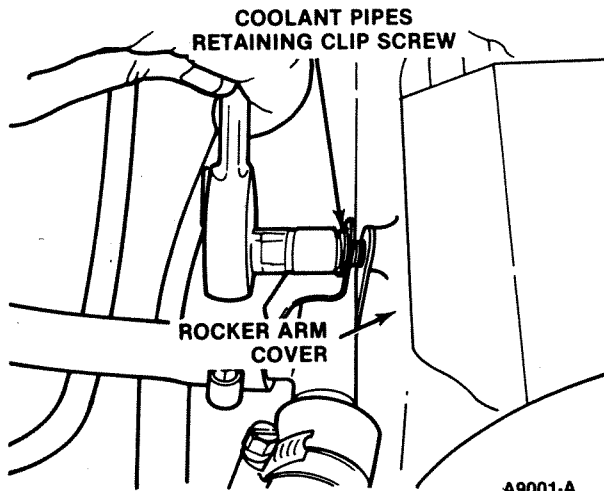

A9001-A

10. Install the coolant return hose at the water pump.

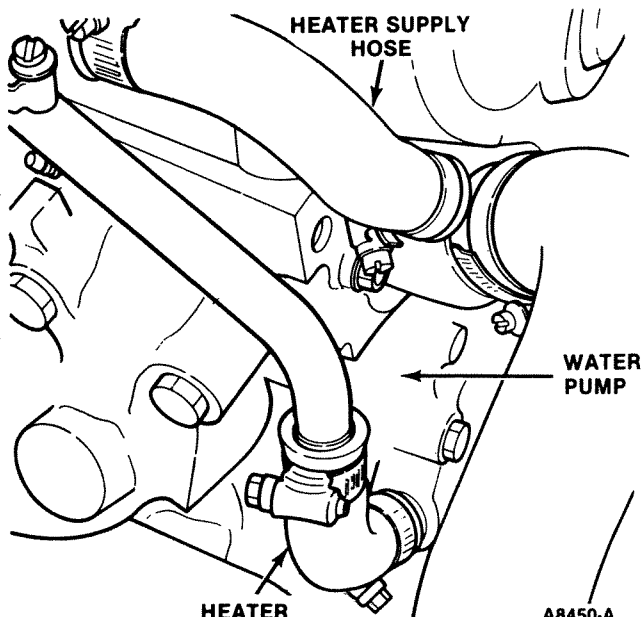

A8450-A

11. Fill the cooling system. If necessary, refer to Section 27-03.

BASE PROCEDURE 18—ASSEMBLY

TIMING BELT INNER COVER INSTALLATION

1. Install the timing belt inner cover, stud bolt and retaining bolts. Torque the stud bolt to 19 to 28 N·m (14 to 21 lb-ft) and the retaining bolts to 8 to 12 N·m (71 to 106 lb-in.).

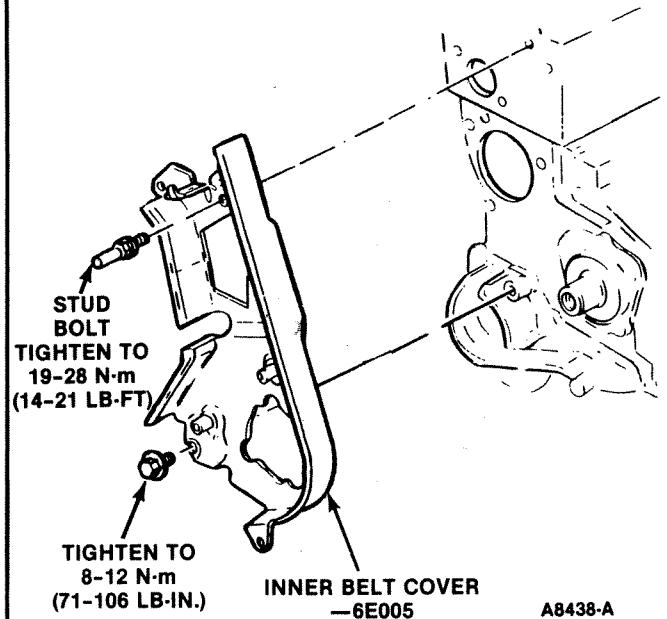

A8438-A

Then complete:

- Base Procedure 15—Assembly, Timing Belt Tensioner Installation
- Base Procedure 13—Assembly, Camshaft Sprocket Installation
- Base Procedure 16—Assembly, Auxiliary Sprocket Installation
- Base Procedure 12—Assembly, Timing Belt Installation
- Base Procedure 14—Assembly, Crankshaft Damper and Pulley Installation
- Base Procedure 7—Assembly, Timing Belt Cover Installation
- Base Procedure 6—Assembly, Water Pump Pulley Installation
- Base Procedure 5—Assembly, Drive Belts Installation

ENGINE COMPONENT ASSEMBLY

BASE PROCEDURE 17—ASSEMBLY

CRANKSHAFT SPROCKET, FRONT COVER SEAL, AND COVER INSTALLATION

SPECIAL SERVICE TOOLS REQUIRED:

Front Seals Replacer	T74P-6150-A
Front Cover Aligner	T74P-6019-B

1. Be sure the front of the cylinder block and front cover are clean.
2. Position the front cover gasket onto the cylinder block. Chassis or wheel bearing grease can be used to hold it in position.

NOTE: It may be necessary to trim the ends of the oil pan to cylinder block front seal if installing a cover without replacing the oil pan gasket.

3. Install the front cover without the seal in it. Start the bolts but leave them loose.

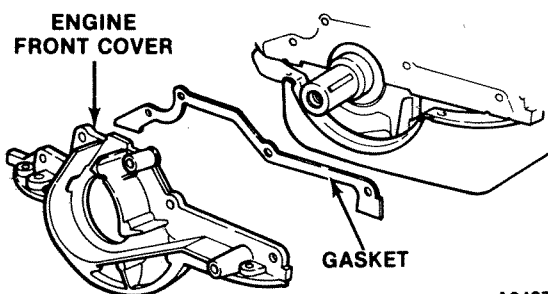

A8437-A

4. Insert engine Front Cover Aligner T74P-6019-B, or equivalent, into the cover to align it with the crankshaft. Torque the bolts to 8 to 12 N·m (6 to 9 lb-ft). Remove the alignment tool.

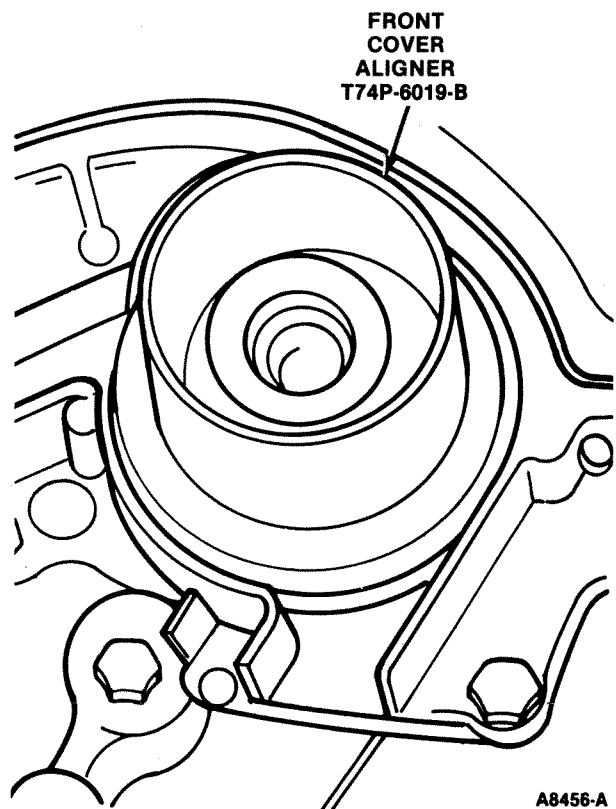

A8456-A

ENGINE COMPONENT ASSEMBLY

BASE PROCEDURE 17—ASSEMBLY

CRANKSHAFT SPROCKET, FRONT COVER SEAL, AND COVER INSTALLATION (Continued)

5. Oil the inner lip of the cover seal and install it using Front Seals Replacer T74P-6150-A, or equivalent.
6. Thread the tool and seal onto the crankshaft. With the outer nut, force the tool and seal toward the engine until the seal bottoms in the front cover. Remove the tool.

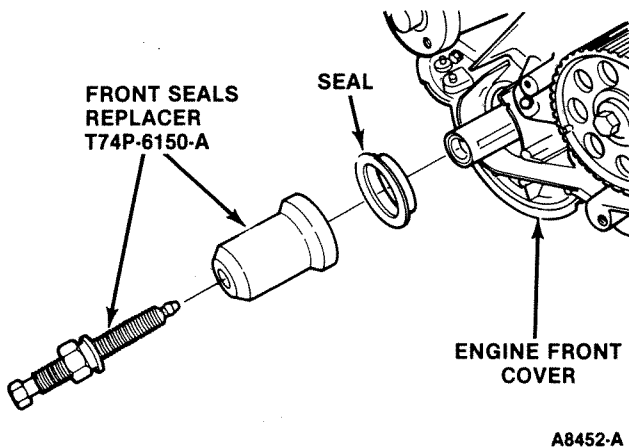

7. Install the crankshaft sprocket. It should slip onto the crankshaft and is retained by the crankshaft pulley.

Then complete:

- Base Procedure 12—Assembly, Timing Belt Installation
- Base Procedure 14—Assembly, Crankshaft Damper and Pulley Installation
- Base Procedure 7—Assembly, Timing Belt Cover Installation
- Base Procedure 6—Assembly, Water Pump Pulley Installation
- Base Procedure 5—Assembly, Drive Belts Installation

BASE PROCEDURE 16—ASSEMBLY

AUXILIARY SHAFT SPROCKET OR SEAL INSTALLATION

SPECIAL SERVICE TOOLS REQUIRED:

Front Seals Replacer T74P-6150-A

Cam Sprocket Holding/Removing T74P-6256-B Tool

1. Be sure the auxiliary shaft and bearings are clean and not worn or damaged.
2. Dip the auxiliary shaft in engine oil.
3. Carefully install the auxiliary shaft in the bearing bores. Do not scratch the bearings.
4. Install the auxiliary shaft retaining plate.

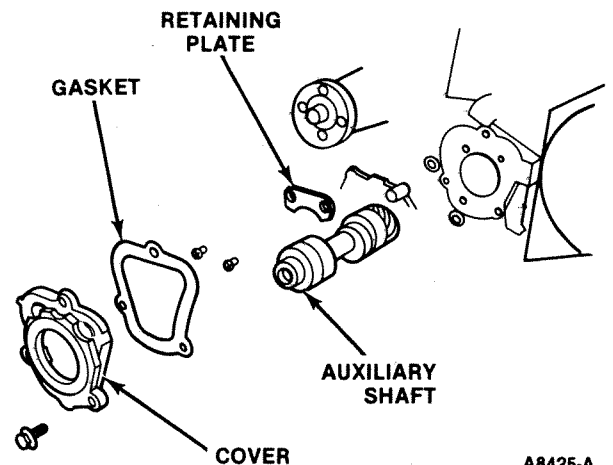

5. Install the auxiliary shaft gasket and cover without the seal. Torque the bolts to 8 to 12 N·m (71 to 106 lb-ft).

ENGINE COMPONENT ASSEMBLY

BASE PROCEDURE 16—ASSEMBLY

AUXILIARY SHAFT SPROCKET OR SEAL INSTALLATION (Continued)

6. Install the auxiliary shaft seal using Front Seals Replacer T74P-6150-A, or equivalent.
7. Install the auxiliary shaft sprocket using Cam Sprocket Holding/Removing Tool T74P-6256-B, or equivalent. Remove the center arbor. The tool is used as a holding fixture. The sprocket retaining bolt presses the sprocket on the shaft. Torque the bolt to 38 to 54 N·m (28 to 40 lb·ft).

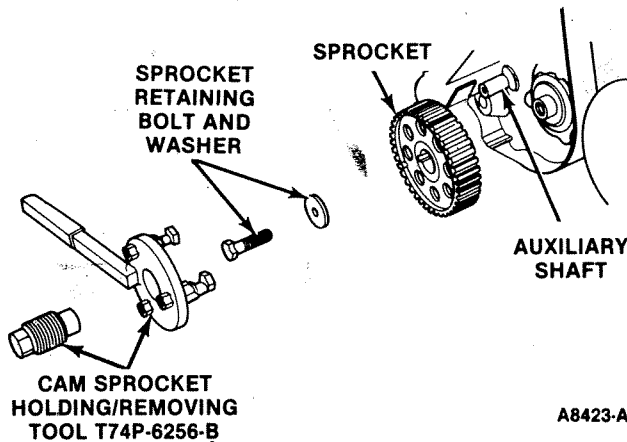

BASE PROCEDURE 15—ASSEMBLY

TIMING BELT TENSIONER INSTALLATION

1. Be sure the timing belt tensioner and the timing sprockets are clean and not worn.
2. Place the timing belt tensioner and spring in position.
3. Install the timing belt tensioner, spring, pivot bolt, and adjustment bolt finger tight.

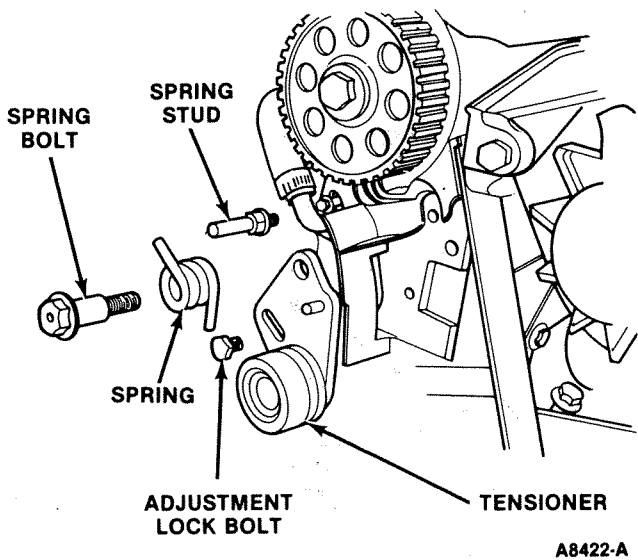

Then complete:

- Base Procedure 12—Assembly, Timing Belt Installation
- Base Procedure 14—Assembly, Crankshaft Damper and Pulley Installation
- Base Procedure 7—Assembly, Timing Belt Cover Installation
- Base Procedure 6—Assembly, Water Pump Pulley Installation
- Base Procedure 5—Assembly, Drive Belts Installation

Then complete:

- Base Procedure 12—Assembly, Timing Belt Installation
- Base Procedure 7—Assembly, Timing Belt Cover Installation
- Base Procedure 14—Assembly, Crankshaft Damper and Pulley Installation
- Base Procedure 6—Assembly, Water Pump Pulley Installation
- Base Procedure 5—Assembly, Drive Belts Installation

ENGINE COMPONENT ASSEMBLY

BASE PROCEDURE 14—ASSEMBLY

CRANKSHAFT DAMPER AND PULLEY
INSTALLATION

1. Be sure the crankshaft damper and pulley are clean and not damaged.
2. Install the damper and pulley onto the crankshaft. Start the retaining bolt.
3. Torque the bolt to 136 to 162 N·m (100 to 120 lb-ft).

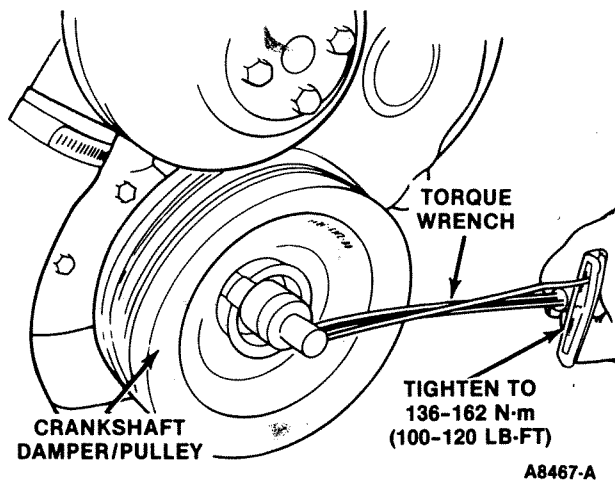
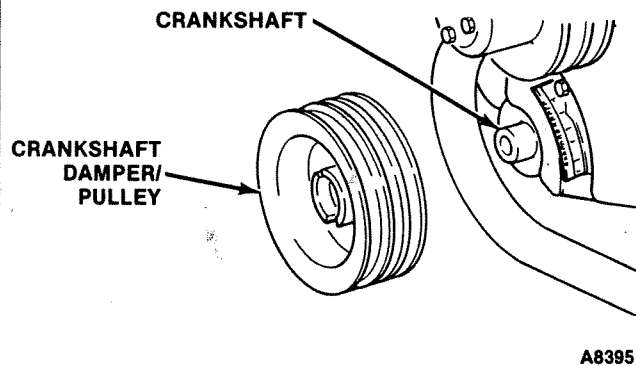

BASE PROCEDURE 13—ASSEMBLY

CAMSHAFT SPROCKET OR SEAL
INSTALLATION

SPECIAL SERVICE TOOLS REQUIRED:

Cam Sprocket Holding/Removing T74P-6256-B
Tool

Front Seals Replacer T74P-6150-A

1. Be sure the seal and seal surface on the camshaft are clean and not damaged.
2. Lubricate the camshaft seal surface and the seal lip with engine oil.
3. Install the seal onto Front Seals Replacer T74P-6150-A, or equivalent.

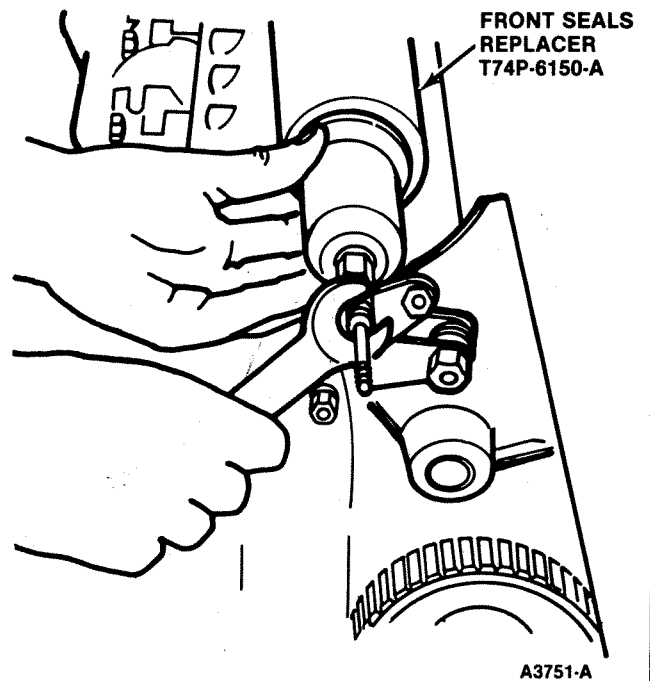

4. Thread the tool arbor into the camshaft.
5. Turn the nut on the tool arbor until the seal is bottomed in its bore in the camshaft front bearing tower.
6. Remove the tool from the camshaft.

ENGINE COMPONENT ASSEMBLY

BASE PROCEDURE 13—ASSEMBLY

CAMSHAFT SPROCKET OR SEAL INSTALLATION (Continued)

7. Install the camshaft sprocket belt guide.
8. Install the camshaft sprocket using Cam Sprocket Holding/Removing Tool T74P-6256-B, or equivalent, as a holding fixture and the sprocket retaining bolt to push the sprocket onto the camshaft.

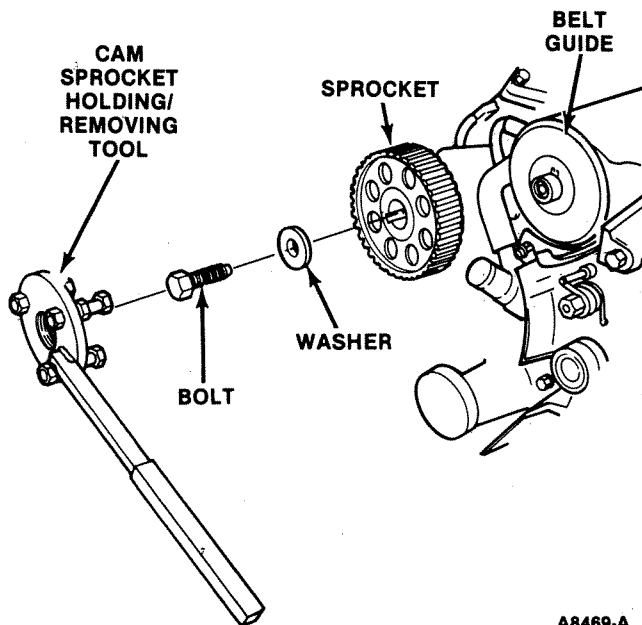

Use a new camshaft sprocket bolt or Teflon tape when installing. Torque the sprocket bolt to 68 to 96 N·m (50 to 71 lb-ft).

Then complete:

- Base Procedure 12—Assembly, Timing Belt Installation
- Base Procedure 7—Assembly, Timing Belt Cover Installation
- Base Procedure 14—Assembly, Crankshaft Damper Installation
- Base Procedure 6—Assembly, Water Pump Pulley Installation
- Base Procedure 5—Assembly, Drive Belts Installation

BASE PROCEDURE 12—ASSEMBLY

TIMING BELT INSTALLATION

SPECIAL SERVICE TOOL REQUIRED:

Camshaft Belt Tensioner Tool T74P-6254-A

1. Be sure the belt and sprockets are clean and not worn or damaged.
2. With the aid of Camshaft Belt Tensioner Tool T74P-6254-A, or equivalent, move the belt tensioner to the no tension position, tighten the adjustment lock bolt and install the belt.

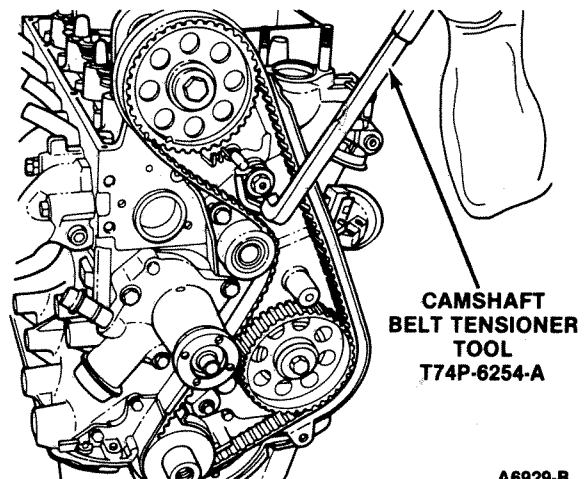

ENGINE COMPONENT DISASSEMBLY

BASE PROCEDURE 12—ASSEMBLY

TIMING BELT INSTALLATION (Continued)

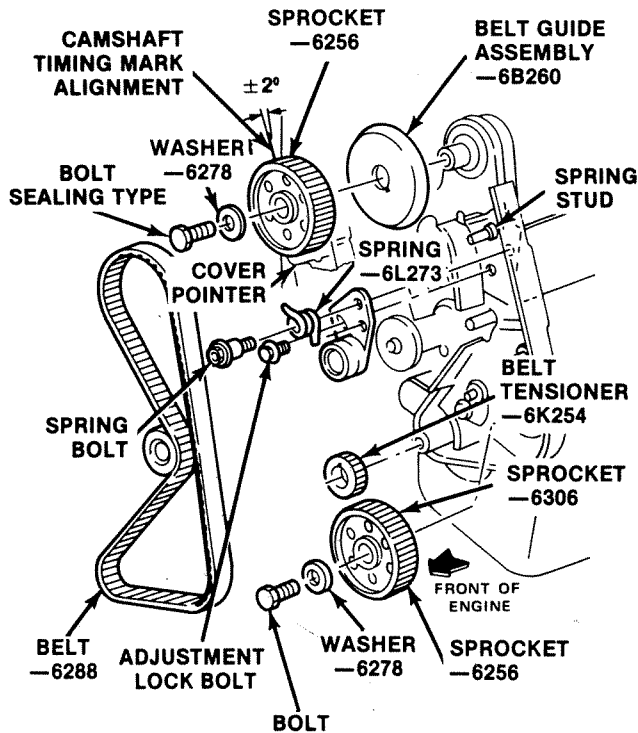

A8421-A

3. Loosen the adjustment lock bolt and allow the tensioner to tighten the belt.
4. Torque the pivot bolt (in the spring) to 38 to 54 N·m (28 to 40 lb-ft) and the adjustment lock bolt to 19 to 28 N·m (14 to 21 lb-ft).

Then complete:

- Base Procedure 14—Assembly, Crankshaft Damper and Pulley Installation
- Base Procedure 7—Assembly, Timing Belt Cover Installation
- Base Procedure 6—Assembly, Water Pump Pulley Installation
- Base Procedure 5—Assembly, Drive Belts Installation

BASE PROCEDURE 11—ASSEMBLY

VALVE SPRINGS AND SEALS INSTALLATION

SPECIAL SERVICE TOOLS REQUIRED:

Valve Seal Installer	T73P-6571-A
Valve Spring Compressor	T74P-6565-A

1. Inspect the valve stems for scores, sticking, excess or obvious stem-to-guide clearance and eccentricity or wobbling when rotated. If any of the above conditions exist, the cylinder head must be removed for further inspection and service. If necessary, refer to the procedure in this section.
2. Apply air pressure through the spark plug holes to hold the valves closed. Install new valve stem seals using Valve Seal Installer T73P-6571-A, or equivalent, and the plastic installation caps.

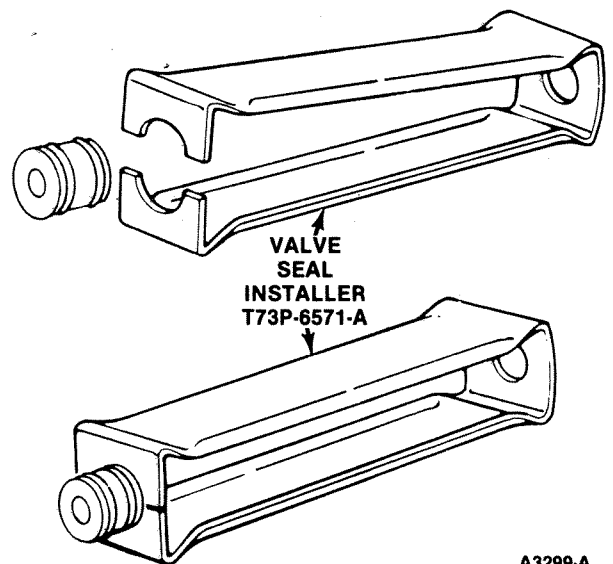

A3299-A

ENGINE COMPONENT ASSEMBLY

BASE PROCEDURE 11—ASSEMBLY

VALVE SPRINGS AND SEALS INSTALLATION
(Continued)

PLASTIC INSTALLATION CAP
(OIL SURFACE OF CAP
TO FACILITATE
SEAL INSTALLATION)

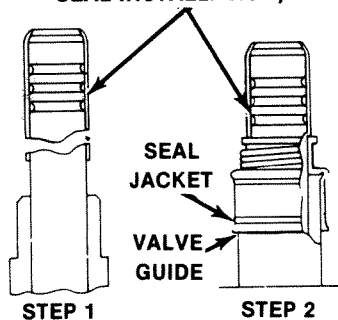

TOOL T73P-6571-A
SHOULD
CONTACT
SHOULDER

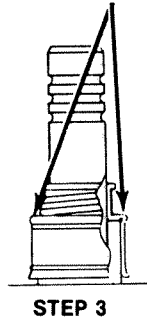

STEP #1— WITH VALVES IN HEAD, PLACE PLASTIC INSTALLATION CAP OVER END OF VALVE SYSTEM.

STEP #2— START VALVE STEM SEAL CAREFULLY OVER CAP. PUSH SEAL DOWN UNTIL JACKET TOUCHES TOP OF GUIDE.

STEP #3— REMOVE PLASTIC INSTALLATION CAP. USE INSTALLATION TOOL T73P-6571-A OR SCREWDRIVERS TO BOTTOM SEAL ON VALVE GUIDE.

A3451-A

3. Install the valve springs, spring retainers and keys using Valve Spring Compressor T74P-6565-A, or equivalent. Remove the air pressure and adapter.

4. Depress the valve springs and install the cam followers.

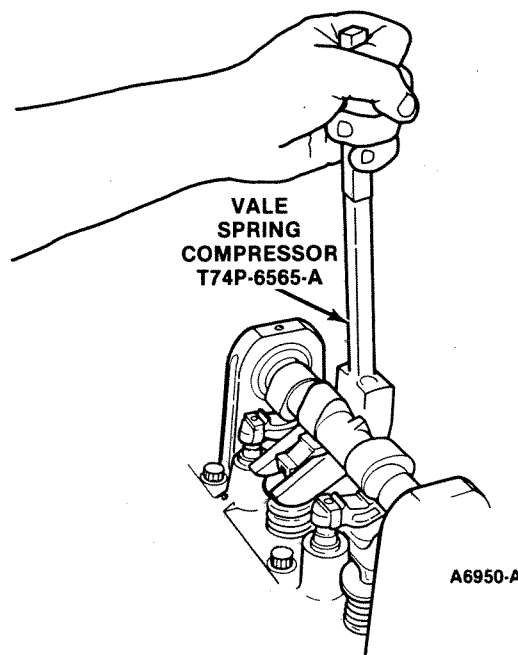

Then complete:

- Base Procedure 9—Assembly, Rocker Arm Cover Installation
- Install the throttle body. Refer to Section 24-29.

ENGINE COMPONENT ASSEMBLY

BASE PROCEDURE 10—ASSEMBLY

HYDRAULIC LASH ADJUSTER INSTALLATION

SPECIAL SERVICE TOOL REQUIRED:

Valve Spring Compressor T74P-6565-A

1. If necessary, rotate engine in its normal direction (crankshaft rotates clockwise) until the base circle of the camshaft lobe, of the hydraulic lash adjuster to be installed, is facing the camshaft.
2. Be sure the lash adjuster bore is clean. Install a new or tested hydraulic lash adjuster into its bore in the cylinder head.
3. Using Valve Spring Compressor T74P-6565-A, or equivalent, depress the applicable valve spring until the cam follower can be inserted into position over the lash adjuster. Fully depress the lash adjuster with the tool and release it.

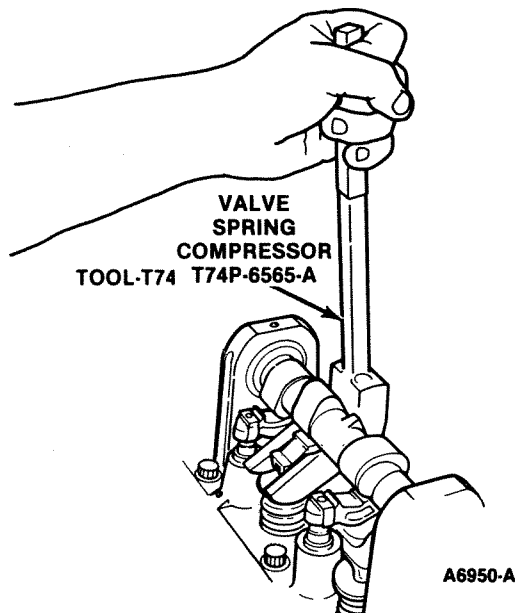

4. Repeat steps 1 through 3 as required.

Then complete:

- Base Procedure 9—Assembly, Rocker Arm Cover Installation
- Throttle Body Installation. Refer to Section 24-29.

BASE PROCEDURE 9—ASSEMBLY

ROCKER ARM COVER INSTALLATION

1. If not previously done, clean the rocker arm cover and cement a new gasket to the sealing surface using D7AZ-19B508-A, or equivalent. Allow to dry past the wet stage.
2. Be sure the cylinder head rocker arm cover sealing surface is clean.
3. Place the rocker arm cover onto the cylinder head.
4. Start the retaining studs and bolts.

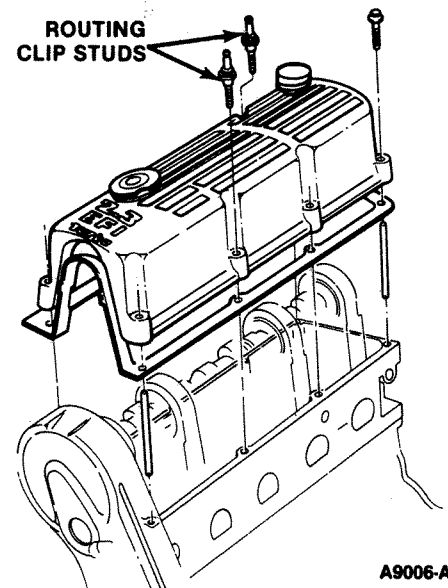

ENGINE COMPONENT ASSEMBLY

BASE PROCEDURE 9—ASSEMBLY

ROCKER ARM COVER INSTALLATION (Continued)

5. Torque the studs and bolts to 7 to 11 N·m (5 to 8 lb-ft).
6. Install the coolant hose supply and return clip screw at the right front side of the rocker arm cover.
7. Install the coolant hose that passes over the rear of the rocker arm cover.
8. Install the PCV hose onto the oil separator on the rocker arm cover.

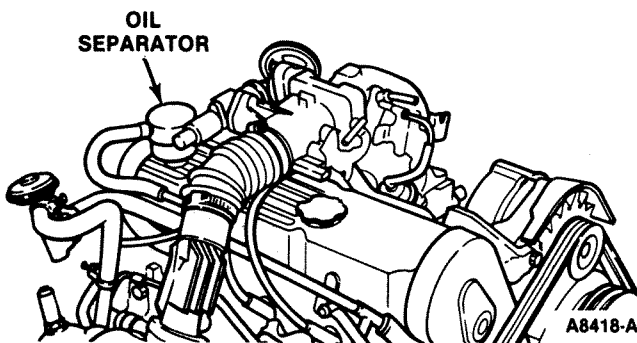

9. Fill the cooling system.

BASE PROCEDURE 8—ASSEMBLY

WATER PUMP INSTALLATION

1. Be sure the water pump gasket surfaces on the water pump and on the cylinder block are clean.
2. Install a new gasket, the water pump bolts, and the water pump onto the cylinder block.

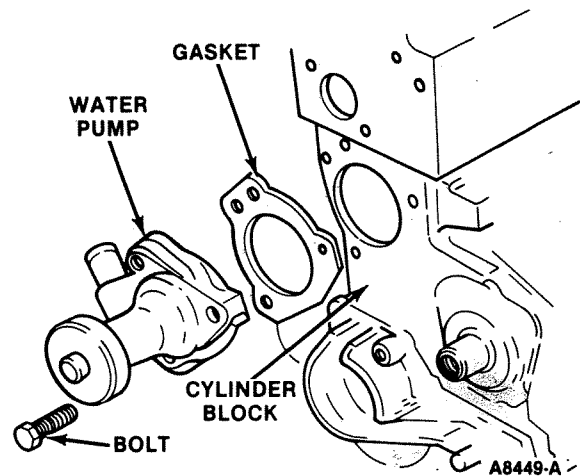

3. Torque the bolts to 19 to 29 N·m (14 to 21 lb-ft).
4. Connect the lower radiator and coolant hoses to the water pump.

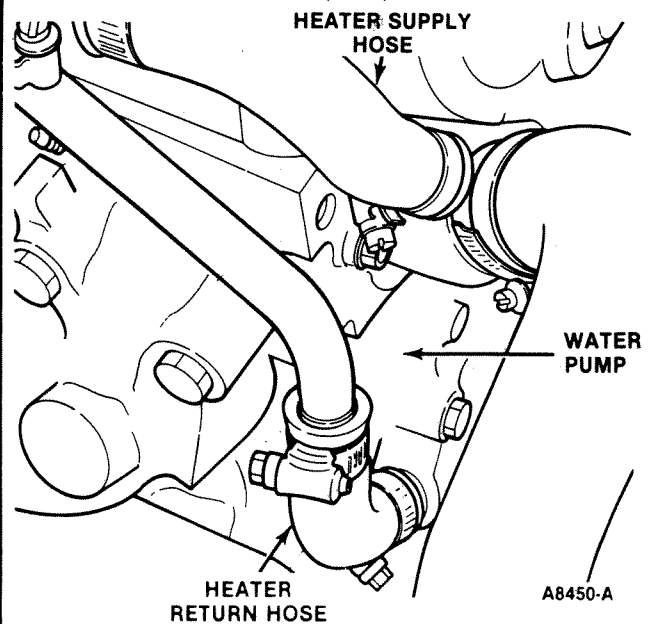

ENGINE COMPONENT ASSEMBLY

BASE PROCEDURE 8—ASSEMBLY

WATER PUMP INSTALLATION (Continued)

5. Fill the cooling system.

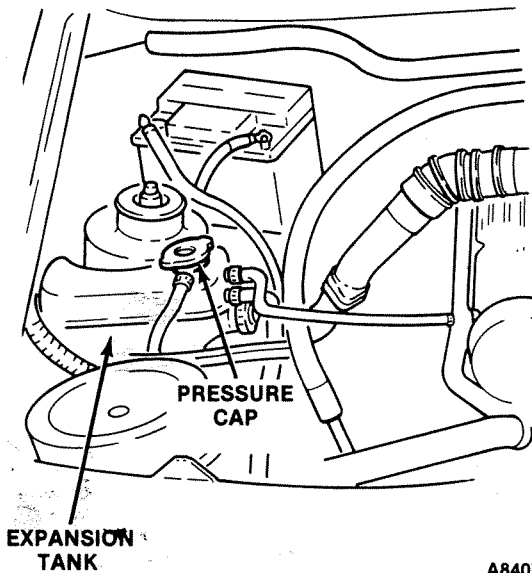

A8407-A

Then complete:

- Base Procedure 7—Assembly, Timing Belt Cover Installation
- Base Procedure 6—Assembly, Water Pump Pulley Installation
- Base Procedure 5—Assembly, Drive Belts Installation

BASE PROCEDURE 7—ASSEMBLY

TIMING BELT COVER INSTALLATION

1. Be sure the cover and its mounting surface on the engine are clean.
2. Install the cover and the four retaining bolts.

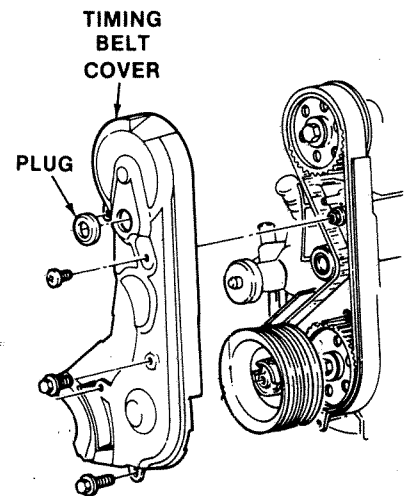

A9005-A

3. Torque the bolts to 8 to 12 N·m (71 to 106 lb-in.).

Then complete:

- Base Procedure 6—Assembly, Water Pump Pulley Installation
- Base Procedure 5—Assembly, Drive Belts Installation